

# INSTRUCTION No. 32 — SPLICING FLEXIBLE STEEL CABLES WITH NICOPRESS® SLEEVES AND TOOLS

## NICOPRESS HAND TOOLS FOR NICOPRESS OVAL AND STOP SLEEVES

# 17-BA	# 51-B4-887	# 51-F2-850	# 3-C-887	# 3-G9-950
# 17-B4	# 51-C-887	# 51-Q-929	# 3-G-887	# 3-Q-929
# 31-B	# 51-G-887	# 51-MJ	# 3-M-850	# 3-MJ
# 31-B4	# 51-M-850	# 63V-XPM	# 3-P-850	# 3V-CGMP
# 32-VC:VG	# 51-P-850	# 64-CGMP	# 3-X-850	# 3V-F6:X:M
# 33V-CGB4	# 51-X-850	# 63V-XPM/Cutter	# 3-F2-850	# 3V-XPM
	# 51-Y-850	# 64-CGMP/Cutter	# 3-F6-950	

### NICOPRESS BENCH TOOL HEADS

The heads used in bench tools are the same as the "heads only" of corresponding *Nicopress hand tools as follows:*

#### No. 510 Bench Tool Heads

# 51-B4-887 Head	# 51-M-850 Head	# 51-F2-850 Head
# 51-C-887 Head	# 51-P-850 Head	# 63V-XPM Head
# 51-G-887 Head	# 51-X-850 Head	# 64-CGMP Head
	# 51-Q-929 Head	# 51-MJ Head
	# 51-Y-850 Head	

No. 510 Bench Tool Heads are completely interchangeable with each other

#### No. 300 Bench Tool Heads

# 3-C-887 Head	# 3-X-850 Head	# 3-Q-929 Head
# 3-G-887 Head	# 3-F2-850 Head	# 3-MJ Head
# 3-M-850 Head	# 3-F6-950 Head	# 3V-CGMP Head
# 3-P-850 Head	# 3-G9-950 Head	# 3V-F6:X:M Head
		# 3V-XPM Head

No. 300 Bench Tool Heads are completely interchangeable with each other

### MAKING SPLICES WITH NICOPRESS OVAL SLEEVES

To make **EYE SPLICES**, pull enough cable through the sleeve so that the end will still protrude after crimping. Line up the sleeve between the tool jaws as shown with the long axis crosswise to the jaws.

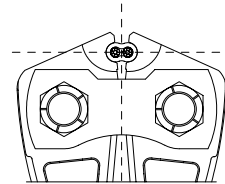
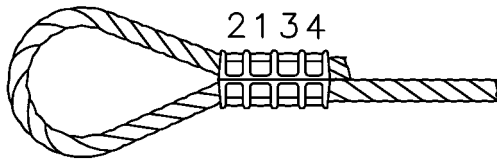

Using the proper NICOPRESS tool, swage the sleeve with the correct number of presses, spacing the presses evenly on the sleeve. If more than 1 compression is required per sleeve, use the pressing sequence shown above. Tables which follow list the number of crimps required for each sleeve. Space crimps apart as shown, except where overlapped crimps are specified. Overlapped crimps are specified for sleeves that need more than one crimp, but do not have room for two complete crimps. Overlapped crimps should compress all of the sleeve. To properly install, it is important the sleeve be fully and correctly pressed. To check this, use the gauge furnished with the tool on a completed sleeve press. Sleeves should enter slot freely. Adjust tool if sleeve does not enter gauge.

For maximum holding strength: Use NICOPRESS Plain Copper Oval Sleeves or Zinc Plated Copper Oval Sleeves on Galvanized Steel Aircraft Cable. Use NICOPRESS Tin Plated Copper Oval Sleeves or Stainless Steel Oval Sleeves on Stainless Steel Aircraft Cable.

**LAP SPLICES** can also be made with *NICOPRESS* Oval Sleeves. Usually 2 sleeves are needed to develop full strength. A short space should be kept between the sleeves as shown. The cable ends should protrude after crimping.

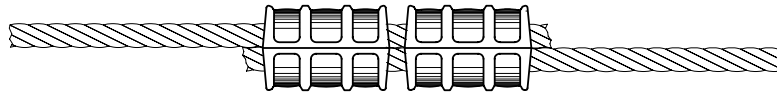

NO. 31-B4 AND NO.32-VC:VG AND NO. 33V-CGB4 TOOLS FOR OVAL SLEEVES			
CABLE SIZE	SLEEVE NUMBER	TOOL GROOVE	CRIMPS REQ'D
3/64	168-1.5-VB4	B4, VB4	2(Overlapped)
	18-11-B4; 28-11-B4; 428-1.5-VB4; 188-1.5-VB4	B4, VB4	1
1/16	18-1-C; 28-1-C; 428-2-VC	VC	1
	188-2-VC	VC	2(Overlapped)
3/32	18-2-G; 28-2-G; 428-3-VG	VG	2(Overlapped)
	188-3-VG	VG	2

NO. 17-BA AND NO. 17-B4 TOOLS FOR OVAL SLEEVES			
CABLE SIZE	SLEEVE NUMBER	TOOL GROOVE	CRIMPS REQ'D
1/32	17-1-B; 27-1-B	B	2
3/64	18-11-B4; 28-11-B4; 428-1.5-VB4	B4	3

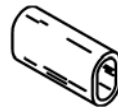
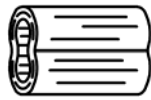

**HAND TOOLS AND NO. 510 BENCH TOOL HEADS FOR OVAL SLEEVES**

CABLE SIZE	SLEEVE NUMBER	HAND TOOL NUMBER	510 BENCH TOOL HEAD NUMBER	TOOL GROOVE	CRIMPS REQUIRED
1/32	168-1-VB; 17-1-B; 27-1-B	31-B		B	1
3/64	168-1.5-VB4; 18-11-B4; 28-11-B4; 188-1.5-VB4; 428-1.5-VB4	51-B4-887	51-B4-887 HEAD	OVAL B4	1
1/16	168-2-VB4	51-B4-887	51-B4-887 HEAD	OVAL B4	1
	18-1-C; 28-1-C; 188-2-VC; 428-2-VC	51-C-887 64-CGMP	51-C-887 HEAD 64-CGMP HEAD	OVAL C	1
3/32	168-3-VC	51-C-887	51-C-887 HEAD	OVAL C	1
	18-2-G; 28-2-G; 428-3-VG	51-G-887 64-CGMP	51-G-887 HEAD 64-CGMP HEAD	OVAL G	1
	188-3-VG	51-G-887 64-CGMP	51-G-887 HEAD 64-CGMP HEAD	OVAL G	2(overlapped)
1/8	168-4-VG	51-G-887	51-G-887 HEAD	OVAL G	1
	18-3-M; 28-3-M; 188-4-VM; 428-4-VM	51-M-850; 64-CGMP; 63V-XPM	51-M-850 HEAD; 64-CGMP HEAD; 63V-XPM HEAD	OVAL M	3
		51-MJ	51-MJ HEAD	M	2
5/32	168-5-VM	51-M-850	51-M-850 HEAD	OVAL M	3
	18-4-P; 28-4-P; 188-5-VP; 428-5-VP	51-P-850; 64-CGMP; 63V-XPM	51-P-850 HEAD; 64-CGMP HEAD; 63V-XPM HEAD	OVAL P	3
3/16	168-6-VP	51-P-850	51-P-850 HEAD	OVAL P	4
	18-6-X; 28-6-X; 188-6-VX; 428-6-VX	51-X-850; 63V-XPM	51-X-850 HEAD; 63V-XPM HEAD	OVAL X	4
7/32	18-8-F2; 28-8-F2; 428-7-VF2	51-F2-850	51-F2-850 HEAD	OVAL F2	4
1/4 - 6x42	18-9-Y	51-Y-850	51-Y-850 HEAD	OVAL Y	3

**HAND TOOLS AND NO. 300 BENCH TOOL HEADS FOR OVAL SLEEVES**

CABLE SIZE	SLEEVE NUMBER	HAND TOOL NUMBER	300 BENCH TOOL HEAD NUMBER	TOOL GROOVE	CRIMPS REQUIRED
3/64	168-1.5-VB4	3-B4-887	3-B4-887 HEAD	OVAL B4	1
1/16	168-2-VB4	3-B4-887	3-B4-887 HEAD	OVAL B4	1
	18-1-C; 28-1-C; 188-2-VC; 428-2-VC	3-C-887 3V-CGMP	3-C-887 HEAD 3V-CGMP HEAD	OVAL C	1
3/32	168-3-VC	3-C-887	3-C-887 HEAD	OVAL C	1
	18-2-G; 28-2-G; 428-3-VG	3-G-887; 3V-CGMP	3-G-887 HEAD; 3V-CGMP HEAD	OVAL G	1
	188-3-VG	3-G-887; 3V-CGMP	3-G-887 HEAD; 3V-CGMP HEAD	OVAL G	2 (overlapped)
1/8	168-4-VG	3-G-887	3-G-887 HEAD	OVAL G	1
	18-3-M; 28-3-M; 188-4-VM; 428-4-VM	3-M-850	3-M-850 HEAD	OVAL M	1
		3V-CGMP; 3V-XPM; 3V-F6:X:M	3V-CGMP HEAD; 3V-XPM HEAD; 3V-F6:X:M HEAD	OVAL M	2
		3-MJ	3-MJ HEAD	M	2
5/32	168-5-VM	3-M-850	3-M-850 HEAD	OVAL M	2 (overlapped)
	18-4-P; 28-4-P; 188-5-VP; 428-5-VP*	3-P-850	3-P-850 HEAD	OVAL P	1*
		3V-CGMP; 3V-XPM	3V-CGMP HEAD; 3V-XPM HEAD	OVAL P	2
3/16	18-6-X; 28-6-X; 188-6-VX; 428-6-VX	3-X-850; 3V-XPM; 3V-F6:X:M	3-X-850 HEAD; 3V-XPM HEAD 3V-F6:X:M HEAD	OVAL X	2
7/32	18-8-F2; 28-8-F2; 428-7-VF2	3-F2-850	3-F2-850 HEAD	OVAL F2	2
1/4	18-10-F6; 28-10-F6; 188-8-VF6; 428-8-VF6	3-F6-950; 3V-F6:X:M	3-F6-950 HEAD; 3V-F6:X:M HEAD	OVAL F6	3
5/16	18-13-G9; 28-13-G9; 428-10-VG9	3-G9-950	3-G9-950 HEAD	OVAL G9	3
	188-10-VG92	3-G9-950	3-G9-950 HEAD	OVAL G9	4

\* This Sleeve-Tool Combination Requires Two Overlapped

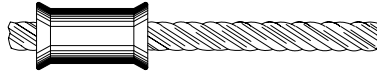

### MAKING TERMINATIONS WITH NICOPRESS® STOP SLEEVES

Cut cable with a sharp, notched, shear type cutter. Thread cable through sleeve so that it extends 1/8". Using the proper NICOPRESS® tool, swage the sleeve with the correct number of presses, spacing the presses evenly on the sleeve. To properly install, it is important the sleeve be fully and correctly pressed. To check this, use the gauge furnished with the tool on a completed sleeve press. Sleeves should enter slot freely. Adjust tool if sleeve does not enter gauge.

HAND TOOLS AND NO. 510 BENCH TOOL HEADS FOR STOP SLEEVES					
CABLE SIZE	SLEEVE NUMBER	HAND TOOL NUMBER	510 BENCH TOOL HEAD NUMBER	TOOL GROOVE	CRIMPS REQUIRED
1/32	871-32-B	17-BA		B	2
		31-B		B	1
3-64	871-12-B4	17-B4		B4	2 (overlapped)
		51-B4-887	51-B4-887 HEAD	OVAL B4	1
		31-B4		B4	1
		33V-CGB4		VB4	1
1/16	871-1-C 878-2-VC	51-C-887	51-C-887 HEAD	OVAL C	1
		32-VC-VG 33V-CGB4		VC	1
		64-CGMP	64-CGMP HEAD	OVAL C	1
	871-1-Q	51-Q-929	51-Q-929 HEAD	Q	1
3/32	871-17-J & 878-3-J	51-MJ	51-MJ HEAD	J	1
	871-3-Q	51-Q-929	51-Q-929 HEAD	Q	1
	871-33-VG	64-CGMP	64-CGMP HEAD	OVAL G	1
1/8	871-18-J & 878-4-J	51-MJ	51-MJ HEAD	J	1
	871-34-VG	64-CGMP	64-CGMP HEAD	OVAL G	1
5/32	871-19-M & 878-5-M	51-MJ	51-MJ HEAD	M	1
	871-35-VM	64-CGMP 63V-XPM	64-CGMP HEAD 63V-XPM HEAD	OVAL M	2
3/16	871-20-M & 878-6-M	51-MJ	51-MJ HEAD	M	1
	871-36-VM	64-CGMP 63V-XPM	64-CGMP HEAD 63V-XPM HEAD	OVAL M	2
7/32	871-22-M	51-MJ	51-MJ HEAD	M	2
	871-37-VM	64-CGMP 63V-XPM	64-CGMP HEAD 63V-XPM HEAD	OVAL M	3

HAND TOOLS AND NO. 300 BENCH TOOL HEADS FOR STOP SLEEVES					
CABLE SIZE	SLEEVE NUMBER	HAND TOOL NUMBER	300 BENCH TOOL HEAD NUMBER	TOOL GROOVE	CRIMPS REQUIRED
1/16	871-1-C & 878-2-VC	3-C-887 3V-CGMP	3-C-887 HEAD 3V-CGMP HEAD	OVAL C	1
	871-1-Q	3-Q-929	3-Q-929 HEAD	Q	1
3/32	871-17-J & 878-3-J	3-MJ	3-MJ HEAD	J	1
	871-3-Q	3-Q-929	3-Q-929 HEAD	Q	1
1/8	871-18-J & 878-4-J	3-MJ	3-MJ HEAD	J	1
5/32	871-19-M & 878-5-M	3-MJ	3-MJ HEAD	M	1
3/16	871-20-M & 878-6-M	3-MJ	3-MJ HEAD	M	1
7/32	871-22-M	3-MJ	3-MJ HEAD	M	2
1/4	871-23-F6 & 878-8-VF6	3-F6-950 3V-F6:X:M	3-F6-950 HEAD 3V-F6:X:M HEAD	OVAL F6	2
9/32	871-24-F6	3-F6-950 3V-F6:X:M	3-F6-950 HEAD 3V-F6:X:M HEAD	OVAL F6	2
5/16	871-26-F6 & 878-10-VF6	3-F6-950 3V-F6:X:M	3-F6-950 HEAD 3V-F6:X:M HEAD	OVAL F6	2
3/8	871-27-F6	3-F6-950 3V-F6:X:M	3-F6-950 HEAD 3V-F6:X:M HEAD	OVAL F6	2

### NOTES:

Sleeve pressing with No. 63V-XPM/Cutter tool or No. 64-CGMP/Cutter tool is done the same way as with No. 63V-XPM tool or No. 64-CGMP tool respectively.

Proof testing is recommended whenever the possibility of personal injury or property damage exists.  
**ALWAYS WEAR SAFETY GLASSES WHEN TOOL IS BEING USED.**

Check a crimped sleeve, as shown, with the go-type gauge provided. If the sleeve will not enter the sleeve freely, adjust tool as outlined below.



### ADJUSTMENT FOR HAND TOOLS LISTED ON PAGE NO. 1

Open handles, loosen locking screw two turns. Turn adjustment screw 1/4 of a turn clockwise. After adjustment, tighten locking screw. Swage sleeve on wire and check with gauge. Repeat if necessary. Clean and oil periodically. Except for some spring at final closing, "empty" tool should work freely. The No. 17-BA tool is not adjustable.

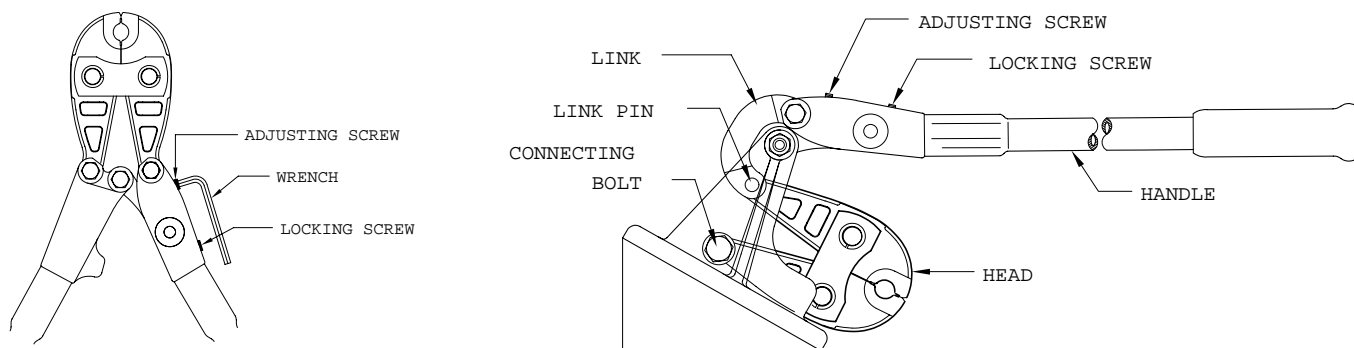

### NO. 300 BENCH TOOL AND NO. 510 BENCH TOOL: ADJUSTING AND CHANGING HEADS

To remove the tool head: (1) Raise the handle to full open position. (2) Remove connecting bolt (see illustration). (3) Pull head out to expose link pin and remove it. To install a tool head, follow the reverse of this procedure. Always check tool adjustment when changing heads (see below).

To adjust the tool, raise the handle to the full open position, loosen the locking screw two turns. Turn adjustment screw 1/4 of a turn clockwise. After adjustment, tighten locking screw. Swage sleeve on wire and check with gauge. Repeat if necessary. Clean and oil periodically. Except for some spring at final closing, "empty" tool should work freely.