

ProCraft AKT Lever Hoists

Compact & Durable Lever Hoist

Main features include:

- Aluminum body construction, light weight and very robust,
- Short handle design
- Load drop protection in free wheeling operation
- Zinc plated grade 80 load chain
- Heavy duty latches, with inspectable hooks
- Each hoist proof load tested to 1.5 times the Working Load Limit
- Low physical effort required on hand;e
- Meets or exceeds ASME B30.21



Capacity tonnes	1/4	1/2
Part # - 5 ft	91PUL-PKT02505	91PUL-PKT05005
Part # - 10 ft	N/A	91PUL-PKT05010

ProCraft AKT Lever Hoists

A compact robust lever hoist, with an aluminum body construction. Suitable for rugged conditions when lifting, pulling, tensioning and moving.

The design and specification of the ProCraft AKT lever hoist includes:

- Range 1/4 Ton & 1/2 Ton
- Very robust with a light weight design, with a short handle design
- Load drop protection in free wheeling operation
- Easy handling with low physical effort required on handle
- Fully protected mechanism for low maintenance costs.
- Heavy duty latches, with inspectable hooks
- Each hoist is proof load tested to 1.5 times the working load limit
- Meets or exceeds ASME B30.21

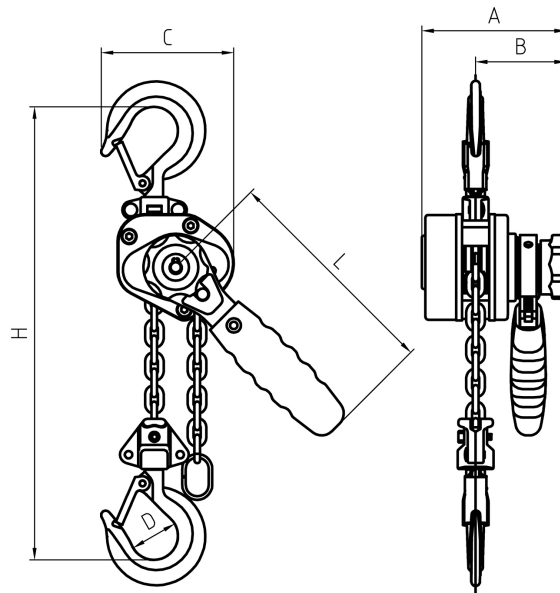

Capacity (tonnes)		0.25	0.5
Model #		AKT025	AKT050
No of Falls		1	1
Load Chain	mm	4.0 x 12.0	4.0 x 12.0
Pull to rated load	lbf	44.9	53.9
Standard Lift	ft	5	5
Net Weight	lbs	5.35	5.51
Extra weight per foot	lbs	0.23	0.23
Dimensions Inches	a	3.97	3.97
	b	2.48	2.48
	c	3.62	3.62
	d	1.26	1.34
	l	6.30	6.30
	h	9.05	9.84